

Driver for 2phase stepping motor

IMS20-210(L)

【User' manual】

MYCOM

MYCOM, INC.

Attention on safety

Please read this user's manual carefully before using and use rightly.

The purpose of this attention is to protect users or others from the injure, damage or loss of property in advance and use this product rightly and safely.



DANGER

This danger shows the possibility that the user may die or get serious injures by fire or electrical shock and the contents which are high emergency of caution when danger is occurred if this warning is neglected and operated.



WARNING

This warning shows the possibility that the user may die or get serious injures, fire or electrical shock if this warning is neglected and operated.



CAUTION

This caution shows the possibility that the user may be injured by electrical shock or the contents which expect to issue physical damage if this caution is neglected and operated.



DANGER

- Do not use the unit broken or disassembled. It may become the cause of fire or electric shock.
- Do not repair or reconstruct by no means because repair and reconstruction may issue a danger which causes serious accident.
- Do not use the unit near by corrosive gas, inflammable gas, explosive atmosphere, watery or oily place or inflammables. It may cause fire, electric shock or injury.
- Only person who has special knowledge is requested to work for setting, wiring, operation, inspection, maintenance and so on. There is a reason of electric shock and injury.
- Keep rated input power voltage range surely. There is a reason of fire or damage.
- Make sure the wiring according to wiring example. There is a reason of fire or damage.
- Do not touch the terminal base during power on by no means because some terminals have high voltage. There is a reason of electric shock.
- Do not put finger or objects on the board. There is a reason of fire or electric shock.
- Do not bent, expand or put into the power cable and motor cable by force. There is a reason of fire and electric shock.
- There is a possibility of fire if motor output terminal and earth or power is connected by mistake.
- Observe the installation method described in user's manual and do not install to prevent radiation. There is a reason of fire.
- If HEAT(Overheat) is effective during operation, stop the operation soon. There is a reason of fire or damage.

 **WARNING**

- Do not operate to move, wire, maintain and test etc. during power on. After power-off and ten seconds pass, please start to operate. It may cause electric shock and injury.
- Do not touch the unit with wet hand by no means during power on. There is a reason of electric shock.
- Connect the protective earth (PE) with the earth terminal (3^d type earth) by no means. It may cause electric shock.
- Install and use the driver in the control box. It may cause electric shock and injure.
- Install terminal cover for terminal during power on. It may cause electric shock and injure.
- Fix the driver tightly when installing. It may cause injury.
- Do not touch the terminal base during power on by no means because some terminals have high voltage. There is a reason of fire and electric shock.
- Do not touch the driver during operation and for the time being after stop. Because the surface of driver is hot depending of operating condition, it may cause injury.

 **CAUTION**

- Do not use or store the unit near by corrosive gas. It may cause damage.
- Do not give a large shock. It may cause malfunctions.
- Do not use or store this unit in a place of high or low temperature, extreme high or low humidity. It may cause a short circuit or malfunctions.
- Avoid dews to form. It may cause a short circuit or malfunctions.
- MYCOM is, in no way, responsible for any damages or malfunctions that are caused by user's repair or modifications on this driver. If the user performed these initiations and the driver does not work satisfactory, a warranty will not be provided.
- When giving up the use of the driver, dispose it according to an appropriate regulation on the industrial waste.
- Please do not remove the name plate.

Index

| | |
|--|----|
| 1. Specification of driver | 1 |
| 2. Model number and Factory default | 2 |
| 2-1. Model number of driver | 2 |
| 2-2. Factory default | 2 |
| 3. Pulse wave | 3 |
| 3-1. Input pulse type | 3 |
| 3-2. Pulse waveform | 3 |
| 4. Each part name and functions | 4 |
| 4-1. Each part name | 4 |
| 4-2. Description of function | 5 |
| 4-2-1. Power indicator LED (POWER) | 5 |
| 4-2-2. Overheat indicator LED (HEAT) | 5 |
| 4-2-3. Excitation timing ZERO output terminal (MONI) | 5 |
| 4-2-4. Motor current shutoff signal (CO) | 5 |
| 4-2-5. Automatic current-off function (A.CO) | 5 |
| 4-2-6. (Automatic current reduction function (A.CD) | 5 |
| 4-2-7. Signal I/O connector (CN) | 6 |
| 4-2-8. Motor connector terminals (MOTOR) | 6 |
| 4-2-9. Power source connector terminal (AC) | 6 |
| 4-2-10. Protective earth terminal (PE) | 6 |
| 5. Example of wiring | 7 |
| 6. Wring and Install condition | 7 |
| 6-1. Wring for motor power lines | 7 |
| 6-2. Applicable clamping terminal | 7 |
| 6-3. Tightening torque for terminal block | 8 |
| 6-4. Install condition | 8 |
| 7. Dimension | 9 |
| 7-1. Dimension | 9 |
| 7-2. Dimension of metal bracket (Option) | 10 |

| |
|---|
| <p>We would ask the trading company or distributor to translate this user's manual into the importer's mother language.</p> |
|---|

1. Specification of driver

| | |
|-----------------------------------|--|
| Model number | IMS20-210(L) |
| Power source | Single phase AC 100-120V \pm 10%, 50/60Hz |
| Power consumption | 240 VA or less |
| Driving type | Bi-polar type |
| Output current | Max. 2.0A /phase |
| Step angle | Basic step (FULL) Half step (HALF) |
| Function | Auto-current-down, Auto-current-off, Driving current-off input Timing output, Overheat output |
| Signal input | 1 clk (PLUSE, CWCCW), 2 clk CW, CCW, CO Photo coupler input : input resistance 390ohm Input signal voltage : L ; 0 to 0.5V, H ; +4 to +5V |
| Signal output | MONI, HEAT (Photo coupler, Open collector output) External usage condition : DC24V or less, 10mA or less. |
| Applicable standard | EN60950 |
| Dielectric Strength | No abnormality detected after the application of 2.0kV(60Hz) between the below terminals for one second. Power input / Motor output terminal – PE terminal Power input / Motor output terminal – Signal I/O terminal |
| Insulation Resistance | 100Mohm or higher with DC500V mega applied to the below terminals in normal temperature and humidity. Power input / Motor output terminal – PE terminal Power input / Motor output terminal – Signal I/O terminal |
| Operating environment temperature | 0 to +40 degree, NO freezing |
| Operating environment humidity | 80% or less, No condensation |
| Storing environmental temperature | -10 to +60 degree, No condensation |
| Storing humidity | 80% or less, No condensation |
| Operating height | Less than 1,000m from sea level |
| Atmosphere | In the room without corrosive gas, inflammable gas and dust. Without splashing water and oil |
| Weight | 650 g (IMS20-210L:500 g) |
| Accessories | User's manual (This book) Terminal cover (1pc.) |

2. Model number and Factory default

2-1. Model number of driver

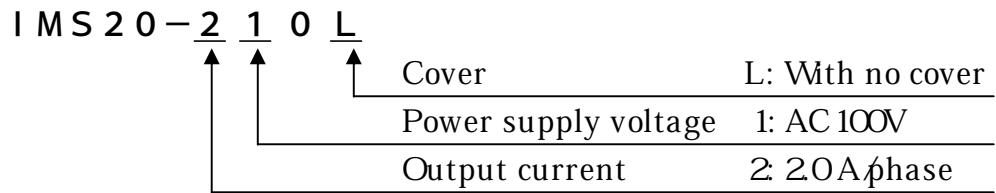

2-2. Factory default

| | |
|----------------------------|--|
| Driver model number | IMS20-210 |
| Driving current | MAX 2.0A/phase |
| Auto-current-off function | Auto-current-off function : release |
| Auto-current-down function | Auto-current-down function : effective |
| Input pulse type | 2 clk type |
| Step angle | Half step |

Please specify if other setting than standard setting is required when ordering.
If not specified, setting is standard and delivered.

3. Pulse wave

3-1. Input pulse type

2 clk type
Timing chart

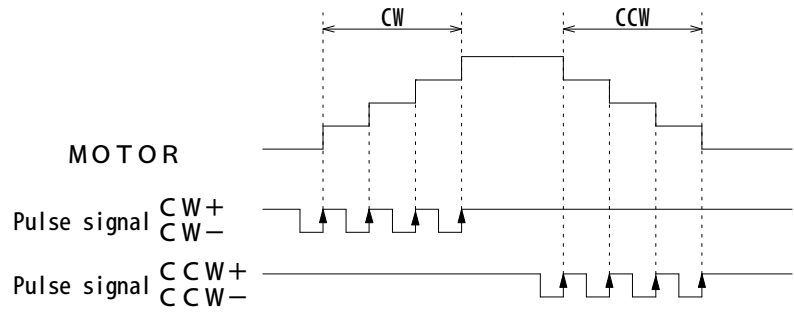

1 clk type
Timing chart

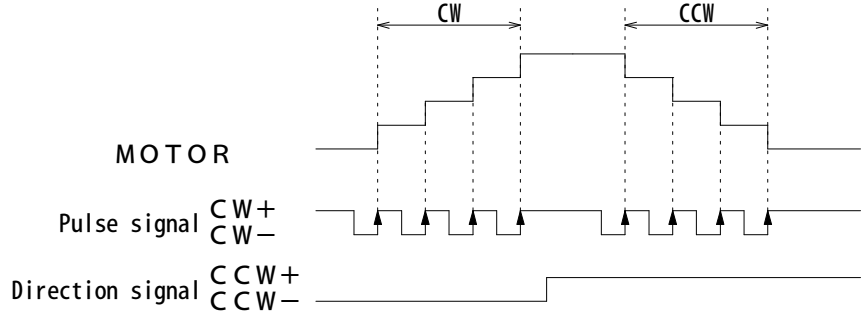

3-2. Pulse waveform

Please input the pulse signal of the below shown waveform.

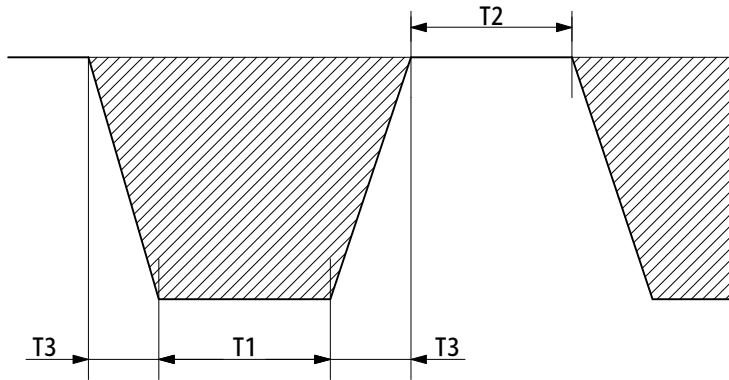

T1 : 10 μ sec or longer
T2 : 30 μ sec or longer
T3 : 2 μ sec or shorter

←this section shows "ON" status of internal photo coupler.

Motor starts to rotate by rising edge of waveform.

4. Each part name and functions

4.1. Each part name

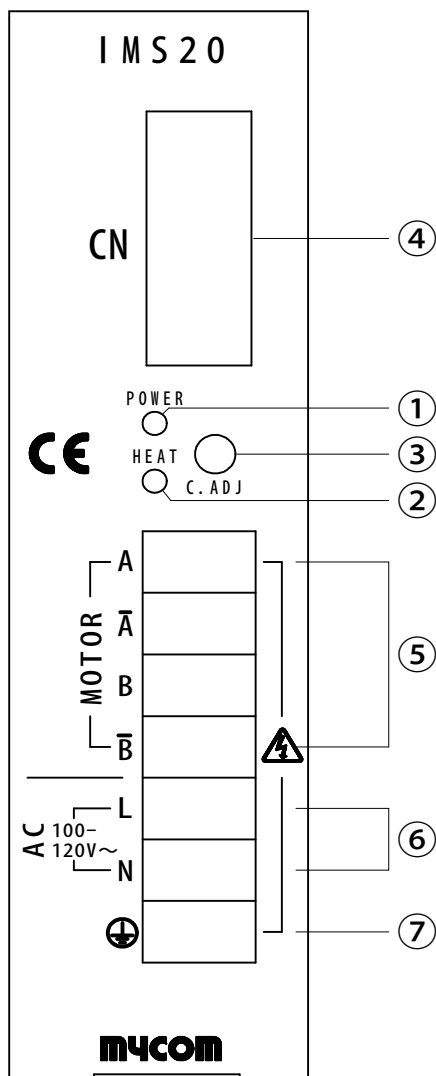

- ① Power display LED
This lights up on during power on.
- ② Overheat display LED
This lights up when the temperature of internal heat-sink rises and becomes overheat condition.
- ③ C.ADJ (Motor run current adjustment)
This VR is pre-adjusted for the applicable motor. This VR is adjustable if a lower current level setting is needed to reduce motor torque and motor driver heat generation.
- ④ Signal I/O connector
Various I/O signals are connected.
- ⑤ Motor connector terminal
Connect color coded motor leads to these terminals.
- ⑥ Power connector terminal
Connect AC line power to these terminals.
- ⑦ Protective earth terminal (PE)
Connect to the protective earth terminal of the machine.

4-2. Description of function

4-2-1. Power indicator LED (POWER)

This lights on during power on.

4-2-2. Overheat indicator LED (HEAT)

This lights on when the temperature of internal heat-sink rises and becomes overheat condition. Then a signal is outputted to the HEAT output of CN.

4-2-3. Excitation timing ZERO output terminal (MONI)

A signal is outputted from MONI terminal of CN when output excitation pattern is excitation timing origin.

4-2-4. Motor current shutoff signal (CO)

Motor winding current turn-on/off signal. When this input terminal of CN is kept ON, the motor shaft can be rotated externally.

H level : Motor winding current-off

L level : Motor winding current-on

4-2-5. Automatic current-off function (A.CO)

This function is to cut automatically all current to motor when the temperature in the driver rises and becomes overheat condition.

4-2-6. (Automatic current reduction function (A.CD)

200ms after the motor stops, the motor winding current is reduced until about 50% of normal driving to minimize motor heating.

4-2-7. Signal I/O connector (CN)

This is to be connected with driving pulse, current off signal and various monitor signals.

| Connector pin assignment | | | |
|--------------------------|------|---|-------|
| 1 | CW+ | 6 | CO- |
| 2 | CW- | 7 | MONI+ |
| 3 | CCW+ | 8 | HEAT+ |
| 4 | CCW- | 9 | COM- |
| 5 | CO+ | | |

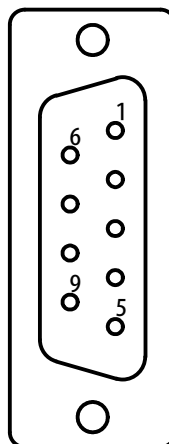

Connector combination 9pin D-sub connector Socket type

Connector : OMRON, XM2D-0901 equivalent

Hood: OMRON, XM2S-0911 equivalent (M2.6×0.45)

4-2-8. Motor connector terminals (MOTOR)

Connect color coded motor leads to these terminals.

4-2-9. Power source connector terminal (AC)

Connect single phase AC 100V-120V, 50/60Hz

18AWG (0.75mm²) leads or larger are recommended.

4-2-10. Protective earth terminal (PE)

Connect with protective earth terminal of the device for safety without fail.

Use bigger leads for protective earth terminal connection than the leads used for power source connector terminal.

5. Example of wiring

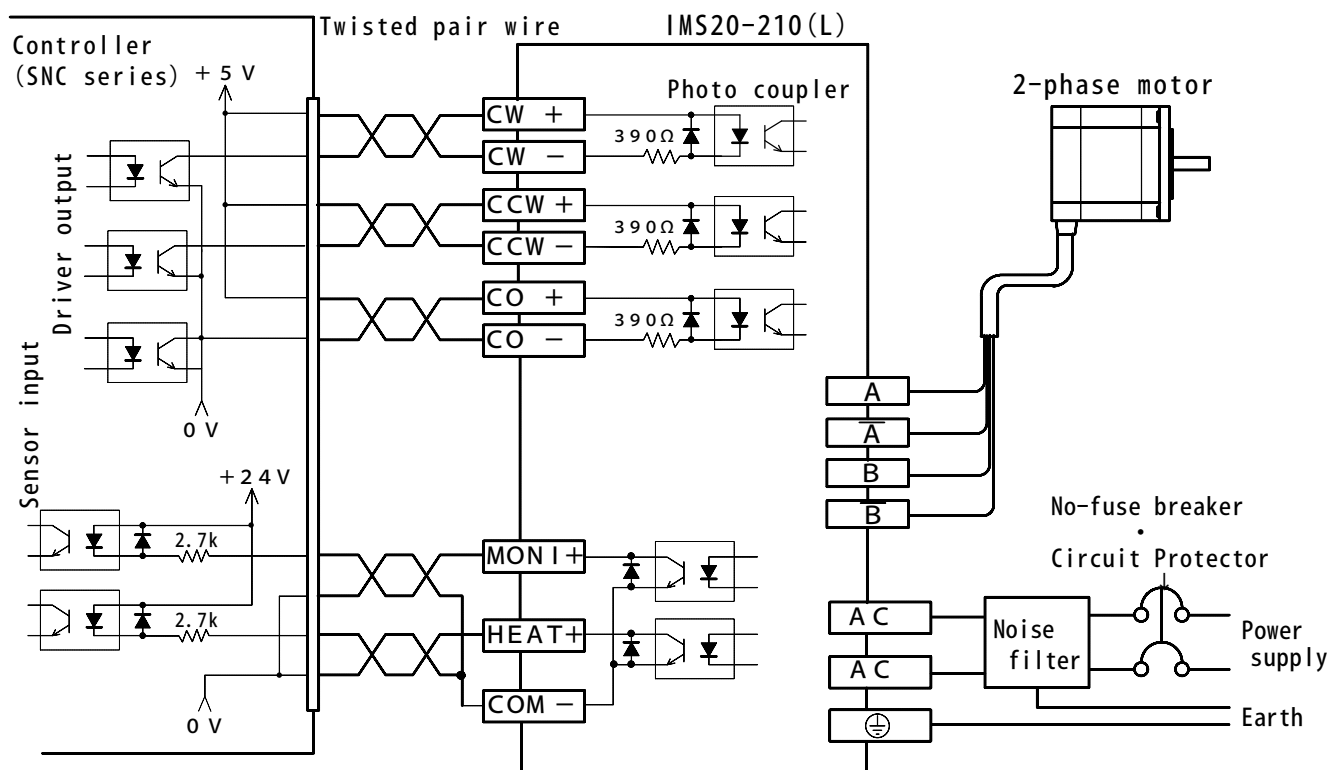

6. Wiring and Install condition

6-1. Wiring for motor power lines

- When wiring, surely wire the protect earth line at first.
- If the motor line is longer, radiant noise can be depressed with shield wire using.
- Install noise filter at power input where noise sources exist near the driver.
- This driver has fuse inside, but use no-fuse-breaker of “3A current capacity” or circuit protector of the capacity of below table for safety.
- It is very dangerous to connect AC power with motor output

6-2. Applicable clamping terminal

Use circle clamping terminal with insulated cover to connect with terminal block.

V1.25-MS3 (J.S.T)

TGV1.25-3 (NICHIFU) or equivalent

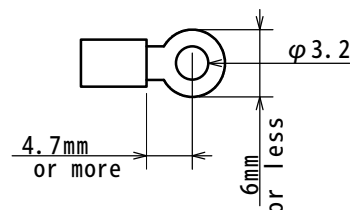

6-3 Tightening torque for terminal block

Tighten the terminal block with torque of 4 to 7 kgfcm when connecting.

6-4 Install condition

- Install the driver in control box. This unit is designed by the following condition.

Over voltage category: Category II, Material group III

Pollution degree: Class 2

Protection structure: IP20(IMS20-210), IP00(IMS20-210L)

Protection against electric shock: Class I component

- Fix driver on heat conductive metal plate tightly.
- Put 3cm or more space between each driver and fix the drivers when multiple drivers are arranged.
- Pay attention not to close the side slits of driver.
- Confirm that the driver environmental temperature is less than 40°C when overheat lamp lights.
- Use screws of “thickness of installing place plus 3 to 5mm” if the driver is installed directly by screws not by accessory bracket.
- Because this unit uses high speed photo coupler for the part of input pulse, use the shield line for signal cable.
- Put this unit vertically because this unit radiates by natural convection. (Refer the below figure)

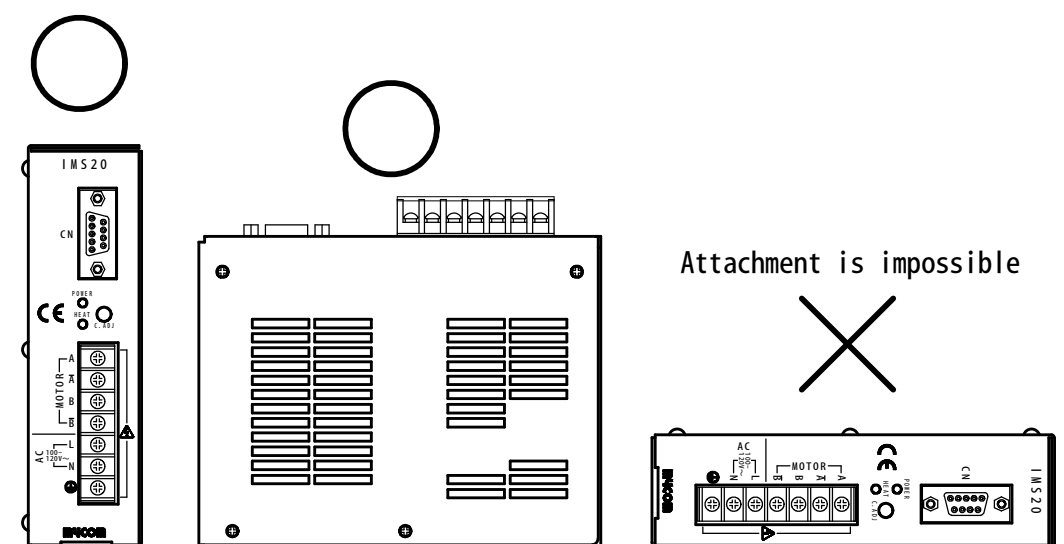

⚠ CAUTION

There is a possibility that driver chassis temperature exceeds 60°C depending on load condition or other environmental condition.

7. Dimension

7-1. Dimension

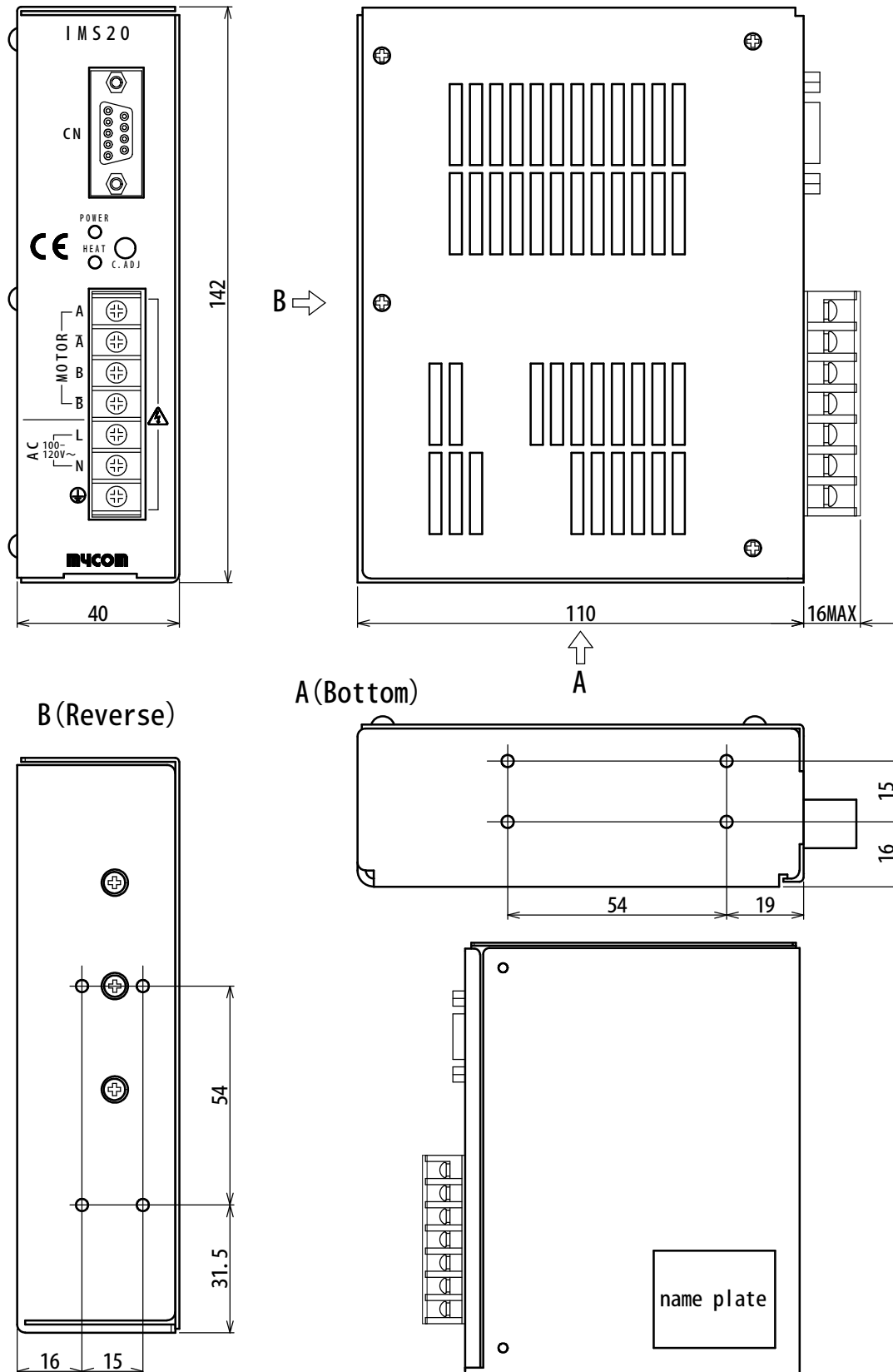

Unit : mm, The screw head is not included.

7-2. Dimension of metal bracket(Optional)

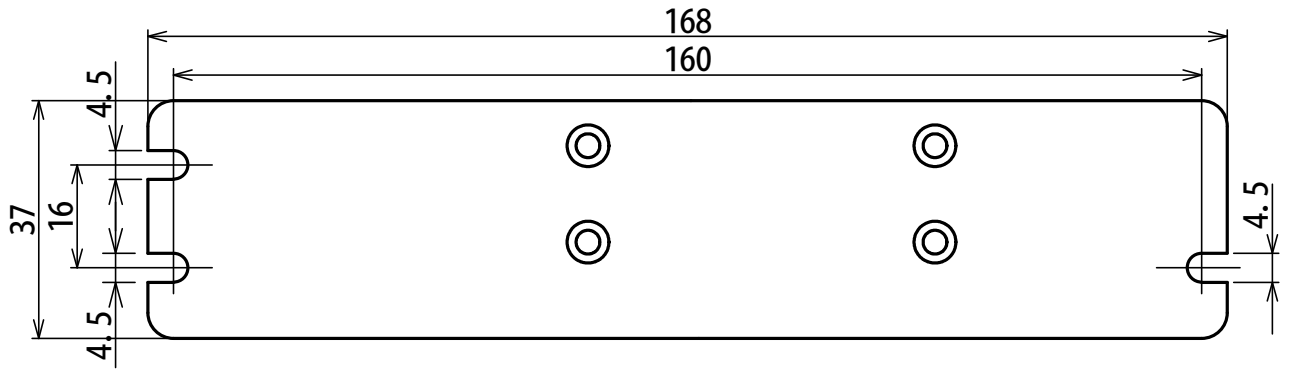

Dimension when option is assembled.

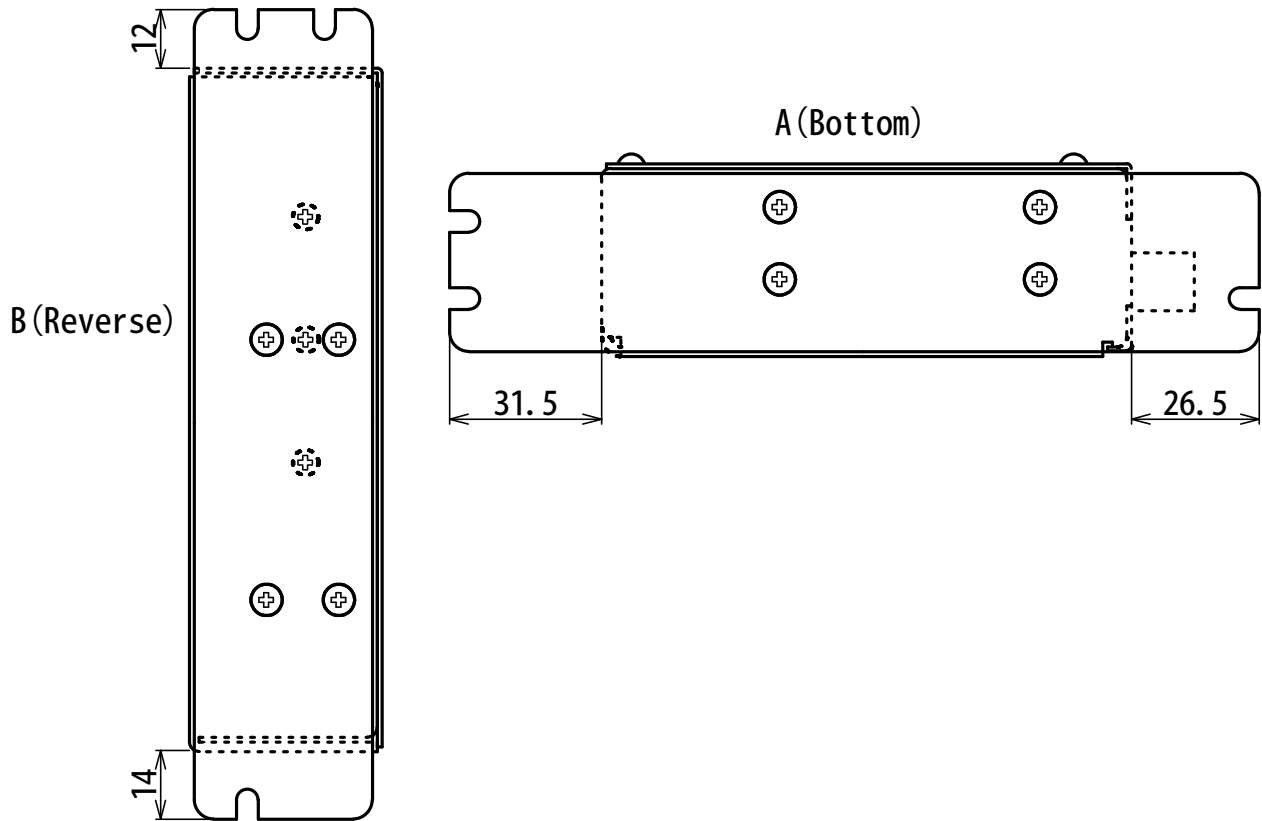

Unit : mm

Please understand that we may make modifications to our products without notification in order to improve the capabilities and external appearance of our products.

MYCOM

MYCOM, INC. (Head office)

12, S. Shimobano, Saga hirosawa, Ukyo, Kyoto, Japan 616-8303

TEL: 81-75-882-3601 FAX: 81-75-882-6531

Home Page : [http //www.mycom-japan.co.jp/](http://www.mycom-japan.co.jp/)

NYDEN CORP.

2610, North First St. #B San Jose, Ca, 95134, USA

TEL: 1-408-232-7700

Home Page: [http //www.nyden.com](http://www.nyden.com)

MYCOM TECHNOLOGY, INC.

2F1., No.333, Fuhsing N, Road Taipei, Taiwan, R.O.C.

TEL : 886-2-2719-0525

MYCOM KOREA, INC.

Rm.301, Keum Chang Bldg. #328-1, 6Ka, Dangsang-Dong Yeoung Dungpo-ku Seoul,
Korea

TEL : 82-2-2635-6703

MYCOM THCHNOLOGY (SINGAPORE) PTE. LTD.

No. 1, Sims Lane #05-05, One Sims Lane, Singapore 387355

TEL : 65-6743-4476

Home Page : [http //www.mycommts.com.sg](http://www.mycommts.com.sg)

Malaysian Contact;

No. 1E-12-07, Jalan Batu Uban, Sunny Ville, Penang, Malaysia

TEL : 60-04-656-0328